



STAINLESS STEEL FLEX LINER (SL) INSTALLATION AND MAINTENANCE INSTRUCTIONS



Listing MH 17528
Tested to UL 1777,
(FOR CHIMNEY LINERS)

Read all instructions carefully before starting installation. Failure to follow these instructions may create a fire or other hazard, and will void the listing and warranty. Metal-Fab's stainless steel flex liner is designed for installation by a qualified person in accordance to local building codes.

IMPORTANT: The flex liner has been tested and listed using all the components described herein. Deletion or modification of any of the required parts or materials as specified in these instructions may impair the safety of the installation and may void the listing and/or warranty of the liner system.

PRODUCT INFORMATION

1. Metal-Fab's stainless steel flex liner system is available in 3" (76 mm) to 8" (203 mm) diameters. It is intended for installation in existing or unlined masonry chimneys used to vent Category I appliances.
2. Liner system is made up of:
 - Stainless Steel Flexible Liner
 - Top Plate
 - Rain Cap
 - Tee or Connector
 - Hardware Package
 - Accessories (As Required)
3. The normal operating temperature for the flex liner is 1000°F (540°C) It has been tested for abnormal intermittent temperatures of 1700°F (927°C) for oil and 2100°F (1150°C) for solid fuels, should temporary appliance malfunction occur.
4. The flex liner is not intended for Category II, III or IV burning appliances.
5. Flex liners used for gas appliances will require using the Metal-Fab MC Series Cap Assembly.

INSTALLATION PRECAUTIONS

1. Contact your local building or fire officials about restrictions and required installation inspections and/or permits in your area.
2. Consult your local building codes before installing liner.
3. Read appliance manufacturer's installation instructions and confirm appliance category and any restrictions or limitations.
4. **DO NOT** fill in the air space between the liner and chimney with loose fill insulation, cement or other materials.
5. Make sure you have proper equipment for the job, including adequate safety protection for working at elevated heights. Always wear gloves and safety glasses when handling sheet metal parts.

6. If a wall penetration assembly is used with the flex liner system, the wall penetration assembly is not to be located directly behind the heating appliance.
7. Do not connect more than one solid fuel burning appliance to a single flue. Do not connect gas or liquid fired appliances to flues serving a solid fuel burning appliance.

SIZING

Proper sizing of the flex liner system to the appliance is very important. Correct sizing of liner is critical for venting of low temperature flue products in geographical areas experiencing sustained low ambient temperatures. Improper sizing may lead to excessive condensation of moisture, creosote buildup and poor draft. The liner must not be sized less than the size specified in the appliance manufacturer's instructions.

MASONRY CHIMNEY INSPECTION

1. Before installing the flex liner system, the chimney passageway should be thoroughly cleaned and any tar glaze creosote removed. Chimney will need to be inspected for cracked, loose or missing bricks, mortar, or other materials that could inhibit correct installation of the liner system.
2. Inspect the air space clearances between the exterior of the masonry chimney and any combustibles. These clearances must be in accordance with NFPA 211 as well as any local building codes.
3. Construction of the chimney will need to meet the following requirements:
 - Minimum brick thickness = 3-1/2" (89 mm)
 - Maximum height = 70 feet (21.3 m)
 - Minimum height = 8 feet (2.4 m)
4. Minimum Inside Chimney Dimensions.

Liner Diameter	Minimum Chimney Dimensions
3" (76 mm)	6" x 6" (152 mm x 152 mm)
4" (102 mm)	7" x 7" (178 mm x 178 mm)
5" (127 mm)	8" x 8" (203 mm x 203 mm)
5.5" (140 mm)	8.5" x 8.5" (216 mm x 216 mm)
6" (152 mm)	9" x 9" (229 mm x 229 mm)
7" (178 mm)	10" x 10" (254 mm x 254 mm)
8" (203 mm)	11" x 11" (279 mm x 279 mm)

5. Termination of the masonry chimney above the roof will need to meet NFPA 211 requirements. Chimneys are required to be at least 3 ft (0.91m) above the highest point they pass through the roof, and at least 2 ft (0.61m) higher than any part of the structure within a 10 ft (3.05m) radius (See FIG. 1).

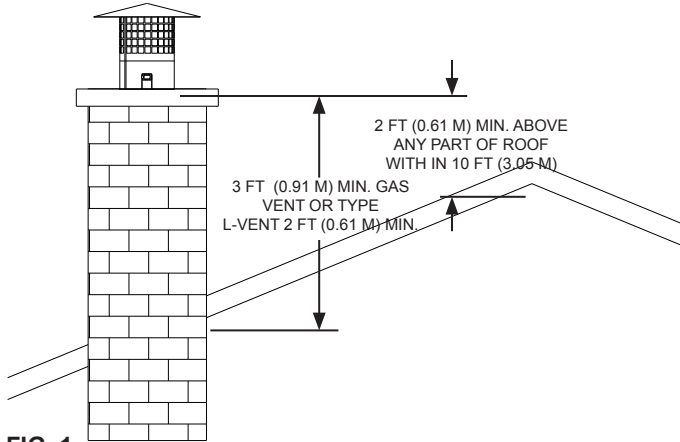

**FIG. 1
LINER CLEARANCES**

1. Clearance from single-wall connectors to combustible material shall be in accordance with NPFA 211 as shown in table below.

Appliance	Min. Clearance
Gas appliances without draft hoods	18" (457 mm)
Oil and solid fuel appliances	18" (457 mm)
Unlisted gas appliance with draft hoods	9" (229 mm)
Oil appliances listed for use with L-Vent	9" (229 mm)
Boilers and furnaces equipped with listed gas burners and with draft hoods	9" (229 mm)
Listed gas appliances with draft hoods	6" (152 mm)

NOTES:

- These clearances apply unless a different clearance is specified by the appliance manufacturer.
 - These clearances do not apply if a listed wall penetration system is used.
2. Clearance between flex liner and masonry and between masonry and combustibles is as shown in the following table.

Fuel Burned	Min. Clearance Liner to Masonry	Min. Clearance Masonry to Combustibles	Insulation Required
Gas/LP	0" (0 mm)	0" (0 mm)	No
Pellet, Oil	1" (25 mm)	1" (25 mm)	No
Wood, Coal	1" (25 mm)	1" (25 mm)	No
Wood, Coal	0" (0 mm)	0" (0 mm)	Yes

LINER PREPARATION (INSULATED)

- Step 1:** Cut the flex liner to required length for installation. If two or more sections of liner are needed to get the desired length, join the sections using a flex connector (See **Joint Connection Instructions**).
- Step 2:** If a Tee is used, insert flex liner into the top of tee body and secure using clamp band (See FIG. 2). Tee Cap should be attached to the bottom of tee Body. **Remove tee branch prior to insulating liner.** The tee is to be insulated along with the liner.
- Step 3:** Roll the 1/2" (13 mm) insulation out on the ground with the foil facing the ground. Place the flex liner system in the middle of the insulation.

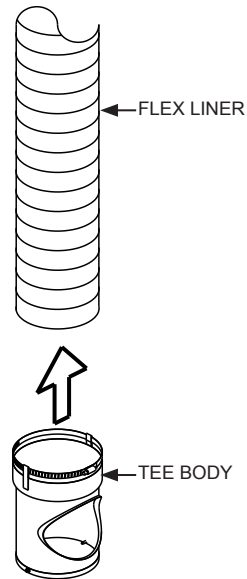

FIG. 2

- Step 4:** Wrap insulation around flex liner and connector (or Tee). Trim the width of insulation as necessary so that edges overlap minimum 1 inch (25 mm). **Do not stretch insulation as this would lessen its thickness and density.**

- Step 5:** Apply spray adhesive to both the flex liner and insulation at 2 foot (0.61 m) intervals. Wrap the insulation tightly around the liner making sure to overlap the seam by about 1 inch (25 mm) as shown in FIG. 3. Secure the seam with foil tape about every 2 feet (0.61 m). Repeat process until the insulation is securely attached to the entire length of liner.

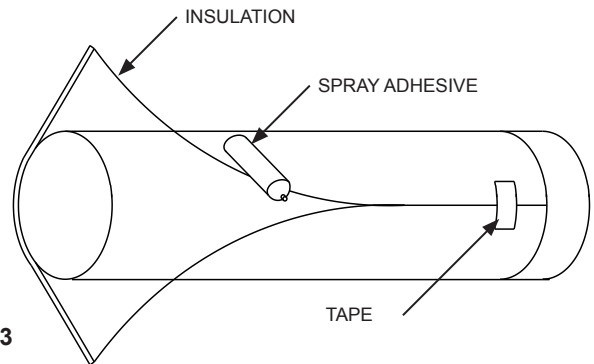

FIG. 3

- Step 6:** Apply foil tape along the entire length of flex liner. Unroll the mesh and slip it around the outside of insulation starting at the bottom end. Pull the mesh up the liner to the top end. Secure mesh to flex liner at bottom with a hose clamp (See FIG. 4). Pull mesh towards top end until it is tight against the insulation and secure with hose clamp.

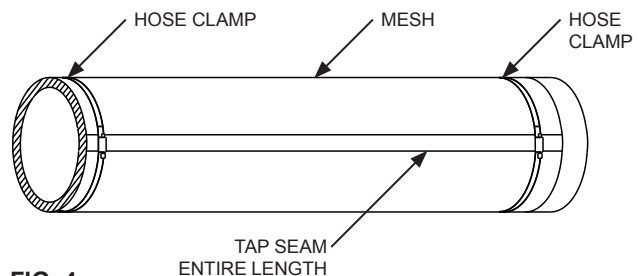

FIG. 4

Liner is now ready to be installed in chimney.

JOINT CONNECTION

1. For taller chimney installations more than one length of flex liner may be needed. Two lengths of liner can be connected together by using a **SLFC** connector.
2. It is important that the connector be installed in the proper direction with flow arrow pointing in the exhaust direction. The female end of the connector should always face towards the top of chimney.
3. Insert connector male end into end of a flex liner length. Secure liner to connector using a minimum three (3) #8 x 1/2" (M4 x 13 mm) self-tapping stainless steel screws or 1/8" (3.5 mm) diameter stainless steel rivets. Pre-drill holes using a 9/64 (3.6 mm) drill bit approximately 1-1/4 inch (32 mm) from edge of liner (See **FIG. 5**). Screws or rivets must be equally spaced around the connector.

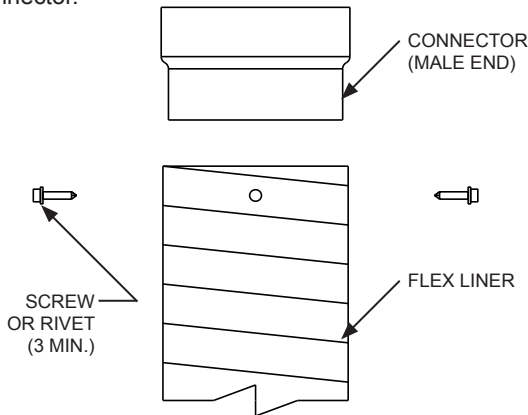

FIG. 5

4. Next insert bottom end of another flex liner length into female end of connector. Attach liner to connector by inserting a minimum three (3) #8 x 1/2" (M4 x 13 mm) self-tapping stainless steel screws into connector's pre-drilled holes. If rivets are used, pre-drill holes in liner and attach with three (3) 1/8" (3 mm) diameter stainless steel rivets (See **FIG. 6**). Screws or rivets must be equally spaced around the connector.

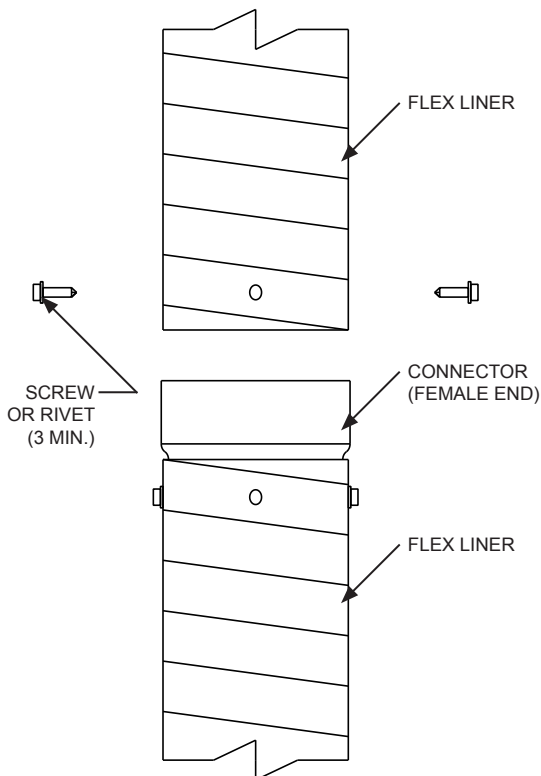

FIG. 6

NOTE: If a **SLFCC** clamp connector is being used, follow steps 1 thru 4, but secure liner to connector using hose clamps (See **FIG. 7**).

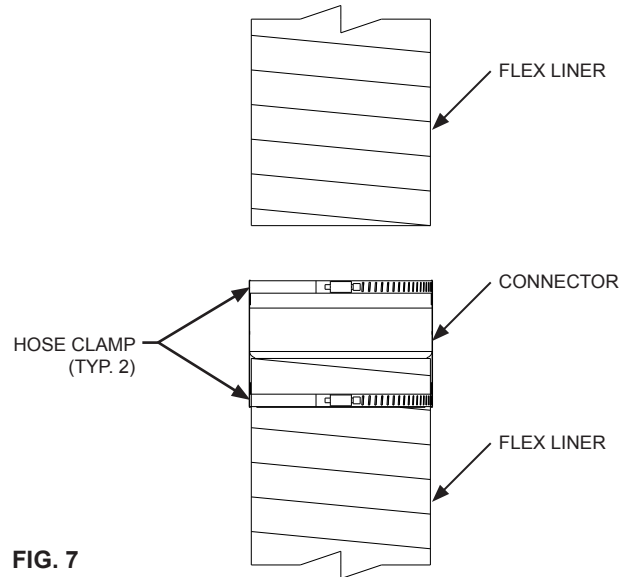

FIG. 7

BASIC STAINLESS FLEX LINER INSTALLATION

Step 1: Measure chimney and record dimensions to determine total flex liner system requirements.

Step 2: Locate where the appliance flue connection will be made in the chimney wall. Break out sufficient masonry to form a hole large enough for the Mortar Sleeve to pass through easily. If a Tee application is being used, refer to the Tee Installation section for details.

Step 3: Remove flex liner from packaging and straighten coiled liner. If liner is to be insulated see **Liner Preparation Instructions**. If liner is not to be insulated, **Spacers will need to be installed every 5 foot (1.5 m) of liner to maintain the 1" (25 mm) clearance required between liner and masonry** (See **FIG. 8**).

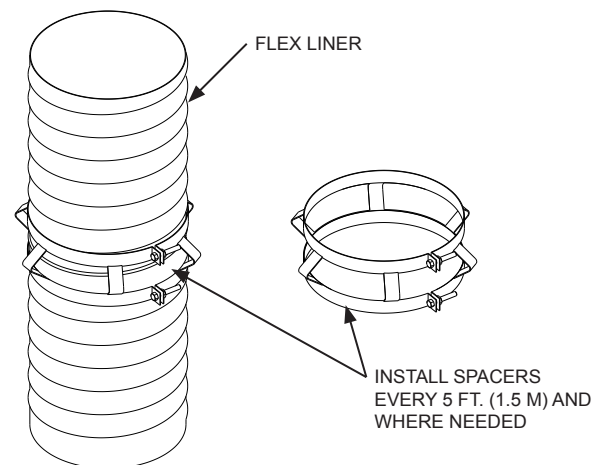

FIG. 8

Step 4: Insert flex liner assembly into chimney by either feeding it from the top or pulling it from the bottom. It is recommended to use two people when pulling the liner through the chimney so as not to tear or damage liner.

Step 5: After flex liner has been fed down the chimney, form a 90° angle at the bottom and bring liner through opening in chimney wall.

Step 6: Slide Mortar Sleeve over flex liner and into masonry until flush (See FIG. 9). After the Mortar Sleeve is in place, the space between the sleeve and masonry may be filled with grout.

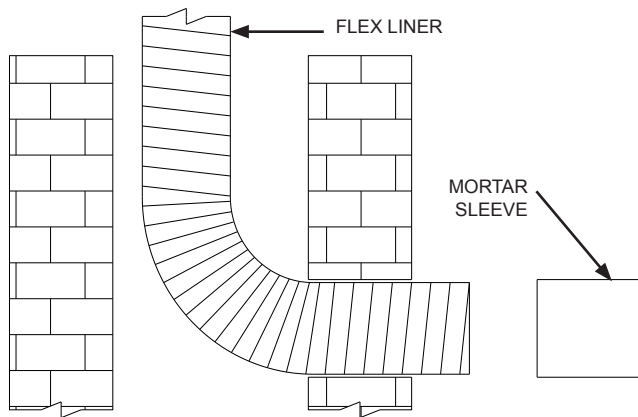

FIG. 9

Step 7: The flex liner should extend a minimum 3 inches (76 mm) beyond Mortar Sleeve. If using a connector to attach flex liner to appliance, attach female end of connector onto liner and secure as described in **Joint Connection** instructions. Be sure the flow arrow on connector is in the same direction of the exhaust flow.

Step 8: Connect flex liner to appliance per appliance manufacturer's instructions. Then connect liner to the Top Plate and Rain Cap per **Termination Installation Instructions**.

TEE INSTALLATION

Step 1: When a Tee is required and the masonry chimney has no offsets, remove the Tee Branch and attach Tee Body to liner with hose clamp (See FIG. 10). Tee Cap should be attached to the bottom of tee Body.

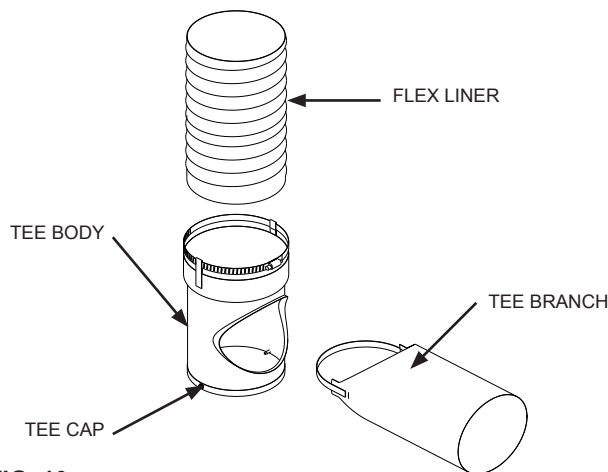

FIG. 10

Step 2: Before lowering the flex liner down chimney, insert the Tee Branch into opening in masonry chimney.

Attach rope securely to Tee Body above the branch and pull flex liner assembly down through chimney. It is recommended to use two people when pulling the liner through the chimney so as not to tear or damage liner.

NOTE: If the masonry chimney has an offset, the Tee Body may need to be rotated to align the Tee Branch opening with opening in chimney. **Make sure to retighten hose clamp after rotating Tee Body.**

Step 3: When the Tee Body is in its final location, remove rope and attach the Tee Branch to Tee Body using the Branch clamp band. Secure Branch by tightening clamp band (See FIG. 11).

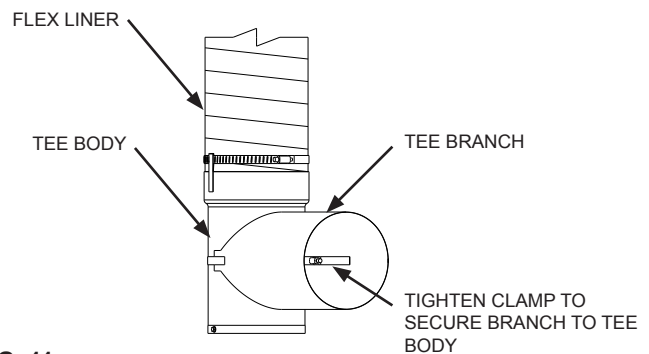

FIG. 11

Step 4: After Tee Body and Tee Branch are installed slide Mortar Sleeve over Branch and into masonry until flush. After the Mortar Sleeve is in place, the space between the sleeve and masonry may be filled with grout.

Step 5: Connect flex liner to appliance per appliance manufacturer's instructions. Then connect liner to the Top Plate and Rain Cap per **Termination Installation Instructions**.

PENETRATION THROUGH A COMBUSTIBLE WALL INTO MASONRY CHIMNEY

When a liner installation is to pass through a combustible wall prior to entering the masonry chimney, some additional installation steps will be required depending on the type of fuel used.

Gas, Oil & Pellet Burning Appliances

Step 1: Gas, oil or pellet appliances will require the use of a Female L-Vent Connector, Flex Wall Thimble and a rigid section of L-Vent pipe.

Verify the required minimum clearance between combustible wall and masonry chimney.

Step 2: Locate the area where the flex liner is to penetrate the vertical wall. Cut and frame an opening so that the flue is centered between vertical wall studs. Required opening is shown in table below.

Liner Dia.	Required Opening
3" (76 mm)	6-1/2" x 6-1/2" (165 mm x 165 mm)
4" (102 mm)	7-1/2" x 7-1/2" (191 mm x 191 mm)
5" (140 mm)	8-1/2" x 8-1/2" (216 mm x 216 mm)
6" (152 mm)	9-1/2" x 9-1/2" (241 mm x 241 mm)

Step 3: Insert liner into masonry chimney as described in these instructions. Attach the **P4FA** Flex Connector to the bottom end of liner and secure with three (3) #8 x 1/4" (M4 x 6 mm) sheet metal screws.

Step 4: After liner is installed, attach a section of rigid pipe to flex connector (**be sure flow arrow is pointed in correct direction**) and secure with twist lock (See FIG. 12).

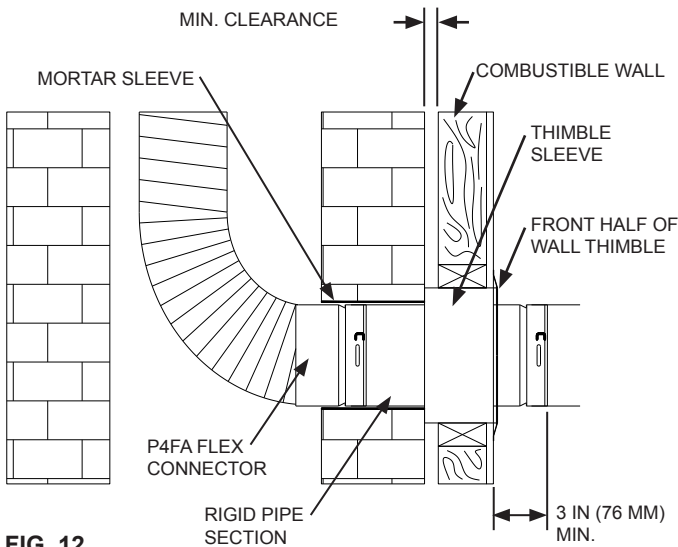

FIG. 12

Step 5: The thimble sleeve will need to extend through the combustible wall and be flush with masonry. Pull the sleeve extension out to required length and secure extension to sleeve with screws. Slide wall thimble over rigid pipe and insert into combustible wall opening. Secure thimble to wall with fasteners. **Rigid pipe must extend out past combustible wall a minimum of 3 inches (76 mm) as shown in FIG. 12.**

Step 6: Connect rigid pipe to appliance per appliance manufacturer's instructions. Then connect liner to the Top Plate and Rain Cap per **Termination Installation Instructions**.

SOLID-FUEL BURNING APPLIANCES

Step 1: Solid-fuel appliances will require the use of TG Flex Connector, TG Wall thimble and a rigid section of TG Pipe (See FIG 13). For insulated flex liners, insulation must also cover the TG Flex Connector.

Verify the required minimum clearance between combustible wall and masonry chimney.

Step 2: Determine where the wall penetration will be located. Cut-out and frame opening in combustible wall per TG Wall Firestop installation instructions (See **L944** for instructions). In masonry wall, cut a 9 inch (229 mm) (6TG) or 11 inch (279 mm) diameter (8TG) opening.

Step 3: Insert TG Flex Connector onto liner and secure as described in Joint Connection instructions. For insulated liners, apply Insulation to liner and to any exposed surface of TG Flex Connector. Then insert liner into masonry chimney as described in these instructions.

Step 4: Insert TG Flex Connector into rigid TG pipe (**be sure flow arrow is pointed in correct direction**). Secure connector to pipe by tightening hose clamp. The rigid TG pipe must extend out past the combustible wall a minimum of 6 inches (152 mm) as shown in FIG 13.

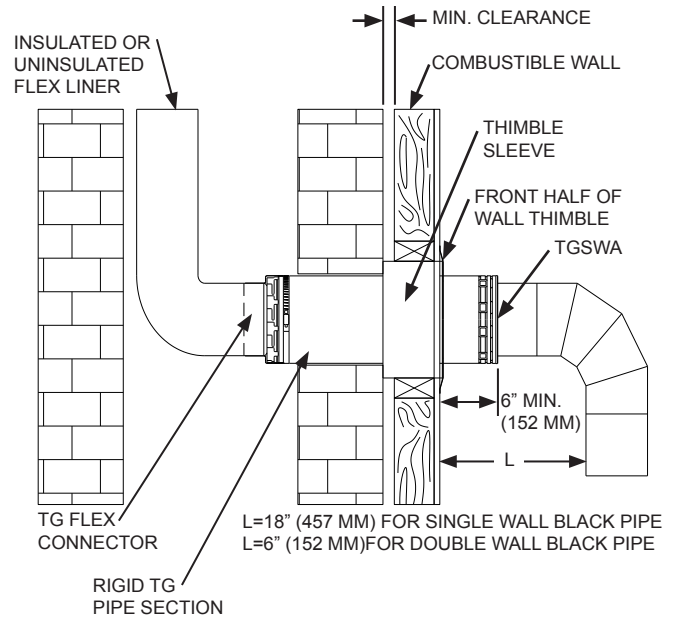

FIG. 13

Step 5: The thimble sleeve will need to extend through the combustible wall and be flush with masonry. Pull the sleeve extension out to required length and secure extension to sleeve with screws. Slide thimble over rigid TG pipe and insert into combustible wall. Secure thimble per **L944** instructions.

Step 6: Connect rigid TG pipe to appliance per appliance manufacturer's instructions. Then connect liner to the Top Plate and Rain Cap per **Termination Installation Instructions**.

NOTES: Finish connection to appliance making sure to keep minimum clearance "L" inches (mm) as shown in FIG. 13.

If transitioning to single-wall TG pipe from the combustible wall, a TGPSWA single-wall adapter will be required.

STOVE PIPE PENETRATION THROUGH A NON-COMBUSTIBLE WALL

- Step 1:** Solid fuel appliances penetrating non-combustible walls require use of DWB Flex Connector, Mortar Sleeve, Trim Collar and rigid section of Black Pipe. For insulated flex liners, insulation must also cover the DWB Flex Connector.
- Step 2:** Locate where appliance flue connection will be made in chimney wall. Break out sufficient masonry to form a hole large enough for Mortar Sleeve to pass through easily.
- Step 3:** Attach female end of DWB Flex Connector onto liner and secure as described in **Joint Connection** instructions. Be sure the flow arrow on connector is in the same direction of the exhaust flow. Insert liner into masonry chimney as described in these instructions.
- Step 4:** Slide Mortar Sleeve over liner and into masonry until flush. After Mortar Sleeve is in place, the space between sleeve and masonry may be filled with grout.
- Step 5:** Slide Trim Collar over rigid Black Pipe section. Attach rigid pipe to DWB Flex Connector (**be sure flow arrow is pointed in correct direction**) and secure by tightening hose clamp (See FIG. 14).

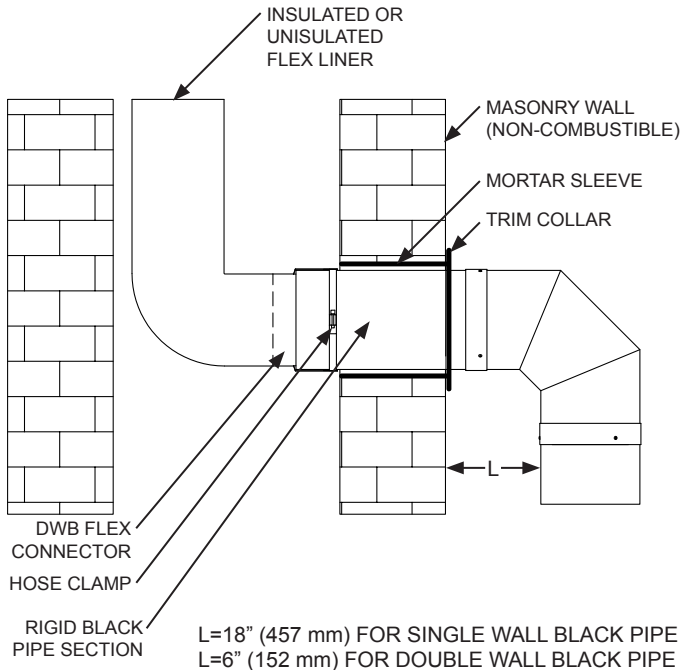

FIG. 14

- Step 6:** Attach Trim Collar to masonry wall to cover opening.
- Step 7:** Connect rigid Black Pipe to appliance per appliance manufacturer's instructions. Then connect liner to Top Plate and Rain Cap per **Termination Installation Instructions**.
- NOTE:** Finish connection to appliance making sure to keep minimum "L" inches (mm) clearance to combustibles from wall or ceiling as shown in FIG. 14.

TERMINATION INSTALLATION

- Step 1:** The flex liner should be terminated approximately 4 inches (102 mm) above the top of the masonry chimney. Cut excess material as necessary.
- NOTE:** Maximum unsupported opening for Top Plate is 14" x 14" (356 mm x 356 mm).
- Step 2:** Slide the Top Plate over the liner and seal to masonry chimney. Trim plate as necessary or fold edges over the outside of chimney. Alternatively, the Top Plate can be secured to chimney using suitable anchors (See FIG. 15). Under extreme heat conditions the liner will expand. A minimum of eight (8) anchors is recommended.

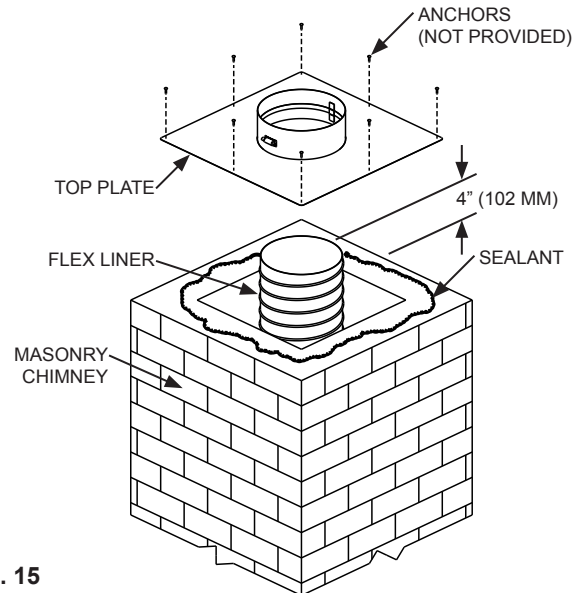

FIG. 15

- Step 3:** Attach the flex liner to support collar using collar hose clamp and secure by tightening (See FIG. 16).
- Step 4:** Slide Rain Cap over support collar so that the notch is centered over the collar hose clamp screw. Secure cap to collar by tightening the cap hose clamp screw (See FIG. 16).

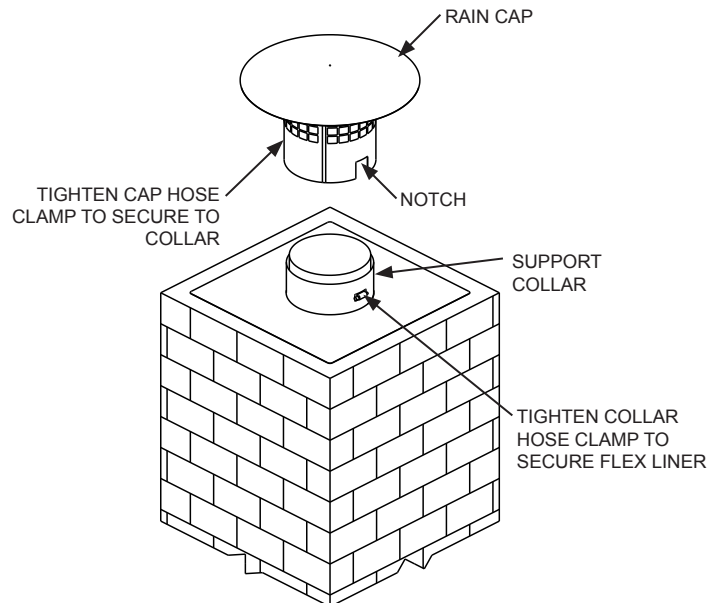

FIG. 16

B-Vent & Pellet Appliances

Step 1: The flex liner should be terminated approximately 4 inches (102 mm) **below** the top of the masonry chimney.

Step 2: Attach the **P12A** flex connector to the liner and secure with three (3) #8 x 1/2" (M4 x 6 mm) sheet metal screws. (See **FIG. 17**).

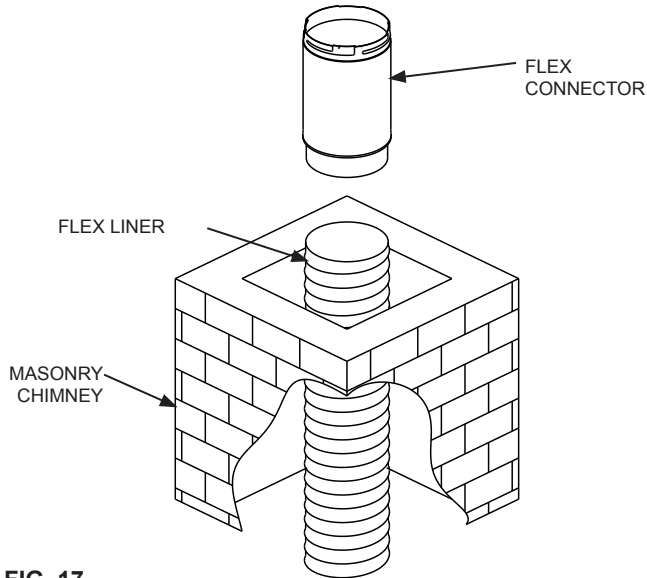

FIG. 17

Step 3: Slide the Top Plate over the Flex Connector and seal the top plate to the masonry chimney (See **FIG 18**). Secure flashing to chimney with suitable anchors.

Step 4: Attach Flex Connector to support collar using collar hose clamp and secure by tightening (See **FIG 18**).

Step 5: Slide storm collar over Flex Connector so that it rests upon support collar. Secure and seal (See **FIG 18**).

Step 6: Attach rain cap to rigid Flex Connector and secure with twist-lock.

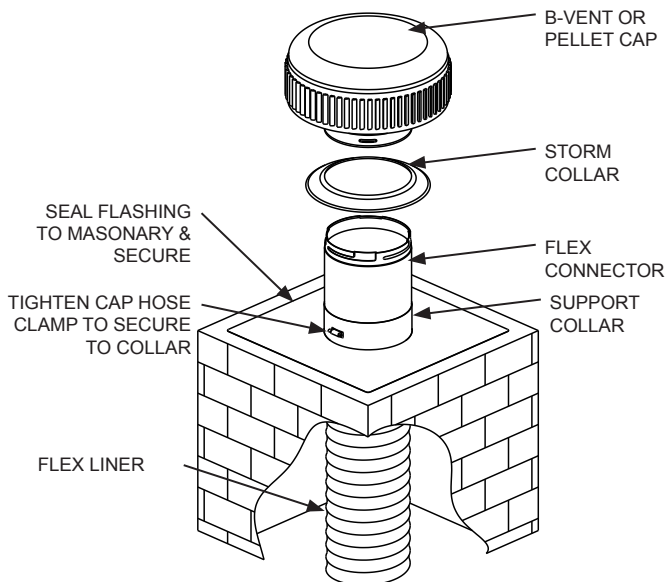

FIG. 18

MAINTENANCE INSTRUCTIONS

WARNING: DO NOT USE ANY MATERIALS/PARTS OTHER THAN SPECIFIED IN THESE INSTRUCTIONS.

1. **Creosote and Soot-Formation and Need for Removal** – When wood is burned slowly it produces tar and other organic vapors, which combine with expelled moisture to form creosote. The creosote vapors may condense on the inside of the flex liner system during slow-burning firing periods. As a result, residue accumulates on the chimney liner. When ignited, this creosote makes an extremely hot fire.

The flex liner system should be inspected at least once every two months during the heating season to determine if a creosote or soot buildup has occurred.

If creosote or soot has accumulated, it should be thoroughly removed using a chimney brush (wire or poly) to reduce risk of a chimney fire. The size of the brush should be approximately 1/8" larger than the diameter of the liner. To access liner, remove rain cap by loosening clamp band (or twist to unlock). **Be sure to reattach the cap after cleaning liner.**

2. It is recommended that the flex liner system be inspected by a qualified chimney inspector, such as a certified chimney sweep, at least once annually following the initial installation of the lining system.

3. The flex liner system is intended to be used only on Category I appliances burning gas, oil, pellet, or solid fuel. For liner systems installed to vent gas and/or oil appliances, posting of notices near the point of connection to the vent is necessary to prevent other type of appliance connections in the future.

4. The heating appliance connected to the liner system must not have a flue outlet size larger than the liner area at its smallest point.

5. Refer to appliance manufacturer's instructions for any precautions to be taken on initial firing of the appliance being vented through the chimney liner.



800-835-2830
P.O. BOX 1138 • WICHITA, KANSAS 67201
(316)943-2351 • FAX (316) 943-2717
info@metal-fabinc.com • www.metal-fabinc.com