

SURE-SEAL DV DIRECT VENT INSTALLATION INSTRUCTIONS

IMPORTANT: DO NOT INSTALL WITHOUT FIRST READING THESE INSTRUCTIONS VERY CAREFULLY. BE SURE TO CHECK APPLIANCE MANUFACTURER'S INSTALLATION INSTRUCTIONS FOR SPECIFIC CLEARANCE TO COMBUSTIBLE REQUIREMENTS. DO NOT EXTEND THE VENTING SYSTEM VERTICALLY OR HORIZONTALLY TO EXCEED THE MAXIMUM DISTANCE PER THE APPLIANCE MANUFACTURER'S INSTALLATION INSTRUCTIONS.

Sure-Seal DV Direct Vent System is manufactured by Metal-Fab, Inc., for use only with direct vent gas fired appliances certified for use with Sure-Seal DV, in accordance with ANSI and CSA gas appliance standards. Sure-Seal DV is listed by OMNI, Warnock Hersey and Underwriters Laboratories Inc. for use on Direct Vent Appliance Systems. Contact Local Building or Fire Officials about restrictions and installation inspection in your area.

Examine all components for possible shipping damage before installation. Proper joint assembly is essential for a safe installation. Check for severe stress of joints upon completion of assembly. Different manufacturers have different joint systems and seal methods. Do not mix pipe, fittings or joining methods from different manufactures. Failure to follow these instructions will void the manufacturer's warranty and may result in serious fire, health or other safety hazards.

CAUTION: Wear gloves while handling sheet metal parts to avoid injury. Be aware of electrical wiring locations in walls / ceilings when installing this product.

GENERAL

There are two basic types of termination options for Direct Vent Systems. Vertical Terminations (See FIG. 1) and Horizontal Terminations (See FIG. 2)

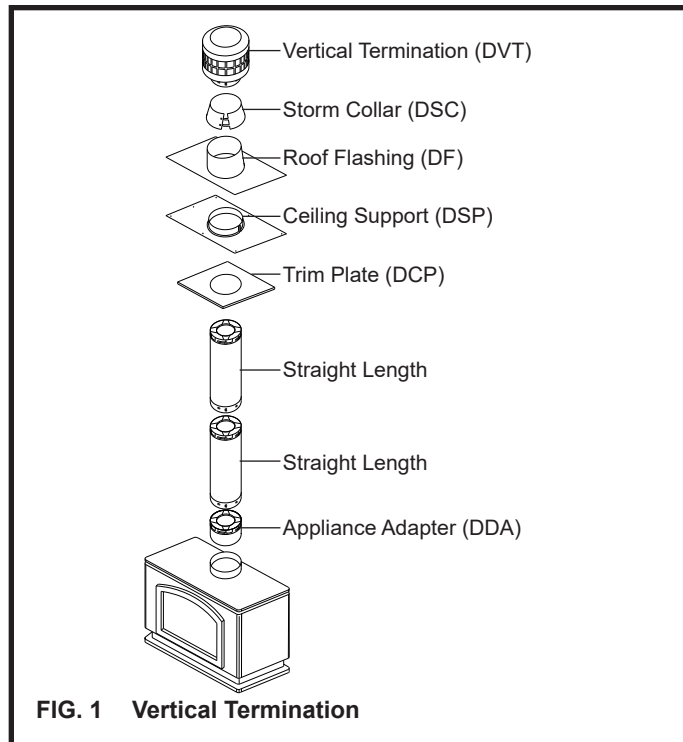

FIG. 1 Vertical Termination

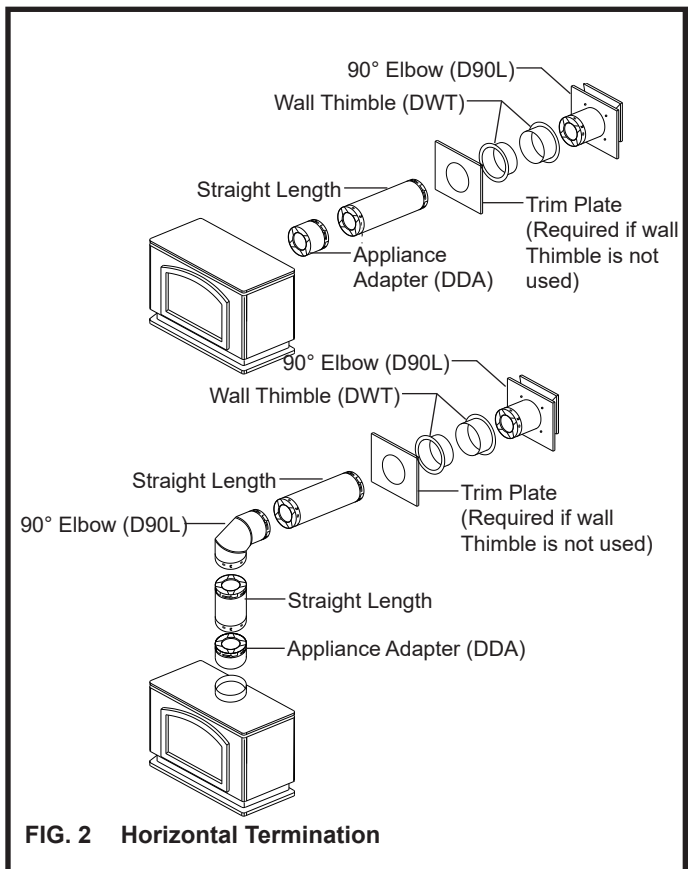

FIG. 2 Horizontal Termination

Follow specific appliance manufacturer's installation instructions regarding proper clearance to combustibles and maximum venting lengths.

APPLIANCE ADAPTER

The Sure-Seal DV appliance adapter (Model 4DDA) is typically used to connect to appliance outlet collars that contain a 4" (ID) by 6-5/8" (OD) collar containing a "Twist Lock" design. For similar appliance outlet collars that measure 5" (ID) and 8" (OD), use appliance adapter (Model 5DDA). These appliance adapters feature a "Twist Lock" joint design. Align the indentations on the female end of the adapter over the entry slots of the appliance outlet collar, slide the adapter down onto the outlet collar and twist in a clockwise motion to secure the joint. (For more information, see the following section **JOINT CONNECTION** to learn about this connection).

Appliance adapter (Model 4DNA) is a universal/Napoleon adapter for use on appliances that have a 4" (ID) and 7" (OD) outlet collar. To install, slide the female end of the adapter over the appliance outlet collar and secure with a minimum of two #8 x 1/4" sheet metal screws and seal with high-temp silicone.

Other adapters may be available. Consult Factory.

INSTALLATION

If the Sure-Seal pipe section fits directly on the appliance outlet collar, proceed with installation. If the fit is loose or results in interference fit, refer to available appliance adapters or contact the appliance manufacturer or Metal-Fab, Inc. with dimensions of appliance outlet for further assistance.

JOINT CONNECTION

Sure-Seal DV Direct Vent components are engineered for easy twist lock assembly. Four indentations are located on the female end of pipe and fittings to slide straight into the male end of the adjacent pipe or fitting, by orientating the four indentations so they match and slide into the four entry slots on the male ends. (See FIG. 3).

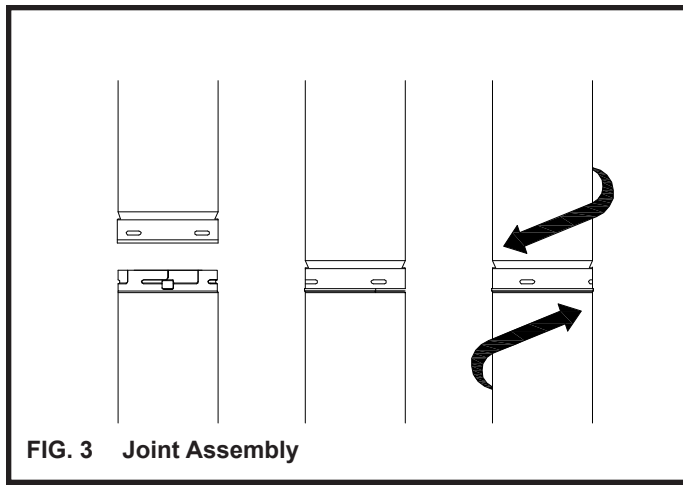

FIG. 3 Joint Assembly

Push the pipe sections completely together, then twist-lock one section clockwise approximately one-quarter turn, until the two sections are fully locked. Indentations on the female end of Black painted pipe and fittings will not be visible unless by examining the inside of the female ends.

Sealant is optional, unless specified by the appliance manufacturer. Should you elect to use sealant, it is only necessary on the outer tube of the Sure-Seal DV vent pipe or fitting. Run a 1/8-inch wide bead of sealant around the male end of the outer sleeve, as shown in FIG. 4, and twist lock the pipes or fittings together.

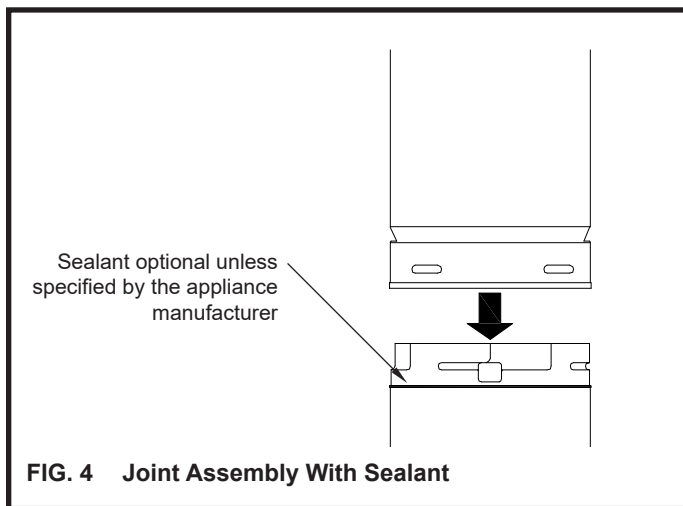

FIG. 4 Joint Assembly With Sealant

SUPPORTS

Sure-Seal DV systems are provided with components to establish horizontal and vertical support upon installation. Some typical cut out dimensions are shown in the chart below to provide adequate clearances for supports:

FRAMING DIMENSIONS			
Sure-Seal DV Diameter	Ceiling Support (DSP) Firestop (DFS)	Cathedral Ceiling Support (DCCS)	Wall Thimble (DWT)
4"	8-5/8" x 8-5/8"	10-3/4" x 10-3/4"	8-3/4" x 8-3/4"
5"	10-1/8" x 10-1/8"	10-3/4" x 10-3/4"	10-1/4" x 10-1/4"

VERTICAL SUPPORT

Sure-Seal DV can be supported vertically in multiple ways. The Ceiling Support (DSP) can be used to provide vertical support by means of a Plate Support and Support Collar. Simply slide Sure-Seal DV pipe section(s) through the Ceiling Support and firmly tighten the Support Collar around the pipe such that the Support Collar rests upon the Plate Support. A square Trim Plate (DCP) is located on the underside of the ceiling to provide a finished appearance once installed (See FIG. 5).

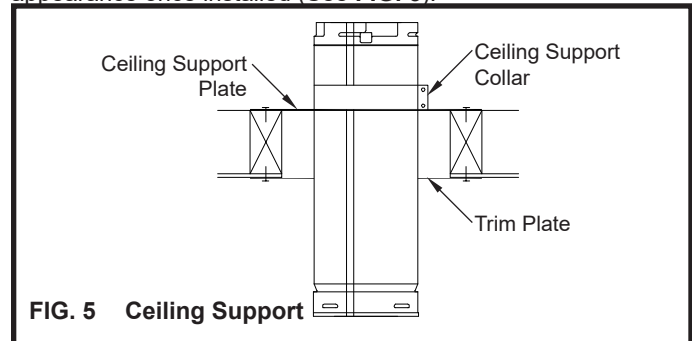

FIG. 5 Ceiling Support

For cathedral (pitched) ceilings, a similar type of support may be provided by using a Cathedral Ceiling Support (DRS). This support box comes with a Support Collar. Install by inserting the Support Box down through the framed cut out in the ceiling. The side of the Support Box with the large round hole should be inserted downward through the ceiling. Using tin snips, cut the corners of the open end of the box so that the sides can be folded down over the top of the ceiling framing members. Nail or screw sides to the top of the framing. (See FIG. 6)

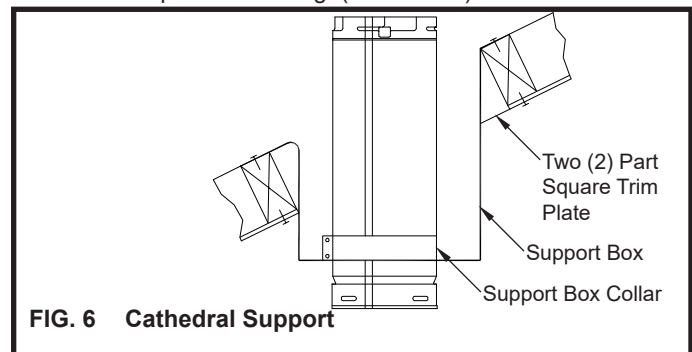

FIG. 6 Cathedral Support

A two-part square Trim Plate is provided to give a finished appearance to the bottom side of the ceiling. To install, fit the two halves of the Trim Plate around the Cathedral Ceiling Support Box (overlapping where necessary) and screw them into the ceiling.

Both support methods can support a maximum of 30 feet of pipe between each support. For further instructions regarding the use of these supports, See Section **VERTICAL INSTALLATION**.

FIRE STOPPING

Sure-Seal DV must be firestopped wherever it passes through floors, ceilings, or walls. Both vertical support methods with trim plates provide for firestopping. The Wall Thimble also acts as a firestop. At other locations (not necessarily support related) a Firestop Spacer (DFS) should be installed. In the attic space, the firestop must be placed on top of the joist framing to prevent debris from falling into the joist framing.

ADJUSTABLE LENGTH

An Adjustable Length (DAL) is provided for installations that require non-standard lengths. The Adjustable Length is a telescopic section of pipe that slips over the male end of standard pipe sections to provide an additional 3" to 10" of pipe length. After positioning the Adjustable Length appropriately, secure it to the standard pipe with two (2) #8x1/4" sheet metal screws. Seal the area around the outer wall overlap using an approved silicone sealant.

HORIZONTAL INSTALLATION

Provided the adapter and pipe attached to the stove is completed, slide the stove into its correct location and mark the wall for a square hole of appropriate size. Use 10" x 10" square hole when using 4" x 6-1/2" pipe and 10-1/2" x 10-1/2" hole when using 5" x 8" pipe. Plan for a level to 1/4" per foot rise from inlet to termination unless otherwise specified by the appliance manufacturer.

Cut and frame the square hole in the exterior wall where the vent will be terminated. The centerline of the pipe should line up with the center of the square hole cut through the wall.

NOTE: Refer to appliance manufacturer's installation

instructions for proper clearance to combustibles.

If the wall penetrated is constructed of non-combustible material only, (i.e. masonry block or concrete) a hole with zero clearance is acceptable.

NOTE: The termination must be located at least 12" above grade, remain above snow line in geographical regions that accumulate snow and be away from traffic areas such as walkways if it is less than 7' high (See FIG. 7).

V = VENT TERMINAL

A = AIR SUPPLY INLET

■ = AREA WHERE TERMINAL IS NOT PERMITTED

	<u>Canadian Installations</u> ¹	<u>US Installations</u> ²
A = Clearance above grade, veranda, porch, deck, or balcony	12 inches (30 cm)	12 inches (30 cm)
B = Clearance to window or door that may be opened	6 inches (15cm) for appliances ≤ and including 10,000 Btuh (3kW), 12 inches (30 cm) for appliances ≤ 100,000 Btuh (30kW), 36 inches (91cm) for appliances ≥ 100,000 Btuh (30kW)	6 inches (15 cm) for appliances ≤ 10,000 Btuh (3 kW), 9 inches (23cm) for appliances ≥ 10,000 Btuh (3 kW) and ≤ 50,000 Btuh (15 kW), 12 inches (30 cm) for appliances ≥ 50,000 Btuh (15 kW)
C = Clearance to permanently closed window	12 inches (30 cm) recommended	9 inches (23 cm) recommended
D = Vertical clearance to ventilated soffit located above the terminal within a horizontal distance of 2 feet (61 cm) from the center line of the terminal	18 inches (45 cm)	18 inches (45 cm)
E = Clearance to unventilated soffit	12 inches (30cm)	12 inches (30 cm)
F = Clearance to outside corner	6 inches (15cm)	6 inches (15cm)
G = Clearance to inside corner	Non-combustible and combustible - As determined by Manufacturer's Installation Instructions	Non-combustible and combustible - As determined by Manufacturer's Installation Instructions
H = Clearance to each side of center line extended above meter/regulator assembly	3 feet (91 cm)	3 feet (91 cm)
I = Clearance to service regulator vent outlet	6 feet (1.83 m)	3 feet (91 cm)
J = Clearance to nonmechanical air supply inlet to building or the combustion air inlet to any other appliance	6 inches (15cm) for appliances ≤ and including 10,000 Btuh (3 kW), 12 inches (30 cm) for appliances ≥ 10,000 Btuh (30kW), 36 inches (91 cm) for appliances ≥ 100,000 Btuh (30kW)	12 inches (30 cm) for appliances ≤ 10,000 Btuh (3 kW), 9 inches (23 cm) for appliances ≥ 10,000 Btuh (3 kW) and ≤ 50,000 Btuh (15 kW), 12 inches (30 cm) for appliances ≥ 50,000 Btuh (15 kW)
K = Clearance to a mechanical air supply inlet	6 feet (1.83 m)	3 feet (91 cm) above if within 10 feet (3 m) horizontally
L = Clearance above paved sidewalk or paved driveway located on public property	7 feet (2.13 m) [*]	7 feet (2.13 m) [*]
M = Clearance under veranda, porch deck, or balcony	18 inches (45 cm) ^{**}	18 inches (45 cm) ^{**}

¹ In accordance with the current CAN/CSA-B149.1-00 Installation Codes
² In accordance with the current ANSI Z223.1/NFPA 54 National Fuel Gas Code
^{*} A vent shall not terminate directly above a sidewalk or paved driveway that is located between two single family dwellings and serves both dwellings.
^{**} Permitted only if veranda, porch, deck, or balcony is fully open on a minimum of two sides beneath the floor.

NOTE: As a general rule, a wall thimble is optional in the U.S. However, there may be some manufacturers that require it. Contact appliance manufacturer for information if uncertain. **When installed in Canada, a Wall Thimble is required on all installations in which the vent passes through a combustible wall.**

If a Wall Thimble is required, begin installation from the outside half of the Wall Thimble and mount it to the outside wall of the building. Secure in place using screws or nails. Seal the perimeter of the face plate to the exterior wall using an RTV Silicone Sealant to provide protection from possible rain entry. (See FIG. 8)

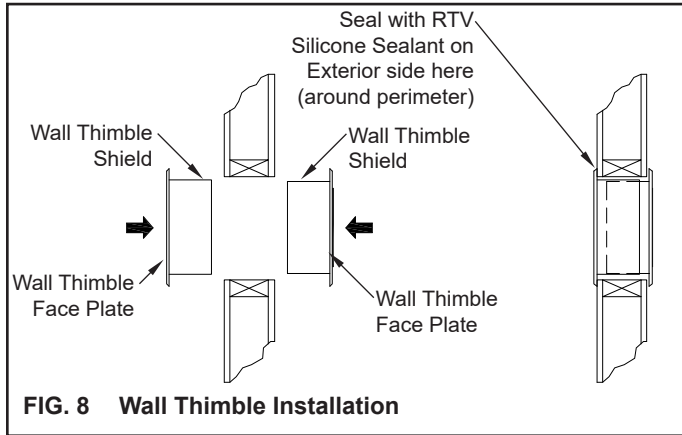

FIG. 8 Wall Thimble Installation

The Wall Thimble allows for installation of wall thickness from 4-1/2" to 7-1/2" walls. If a thicker wall is penetrated, it is allowable to fabricate a metal collar of similar metal thickness and type to extend the length of the Wall Thimble.

To install the Horizontal Termination, position the termination in the center of the square hole in the wall and attach to the exterior wall with the four wood screws provided. Before attaching the termination to the exterior wall, run a bead of non-hardening sealant around the termination's outside edges, so as to make a seal between it and the wall. **The HOT arrow on the vent cap should be pointed up.** Verify that proper clearances are maintained. (See FIG. 9)

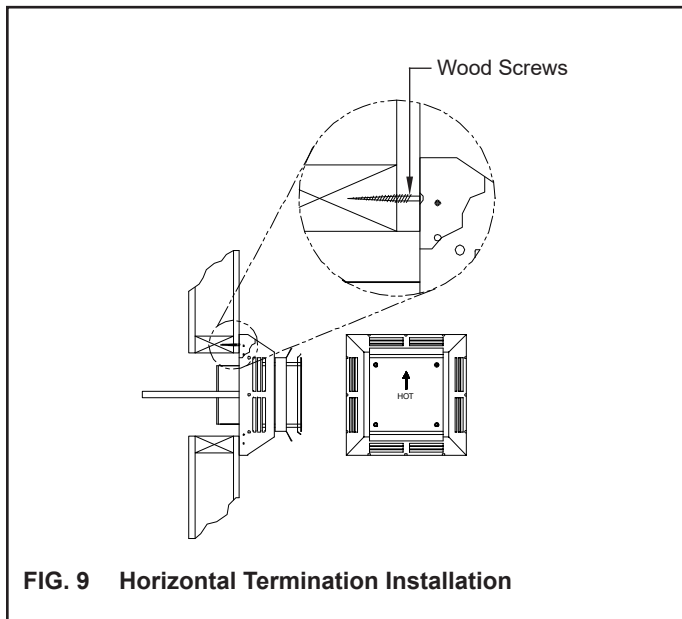

FIG. 9 Horizontal Termination Installation

For exterior surfaces that include stucco, brick concrete or other type sidings, replace the four wood screws provided with other types of appropriate fasteners.

For buildings with vinyl siding, a Vinyl Siding Spacer (DVS) should be installed between the vent cap and the exterior wall. (See FIG. 10). Attach the Vinyl Siding Spacer to the Horizontal Termination. The Vinyl Siding Spacer prevents excessive heat from melting the vinyl siding material. Orientate the Vinyl Siding Spacer such that the Horizontal Termination slips over and is then attached to the inner shaded area of the Spacer as shown using four (4) bolts and nuts.

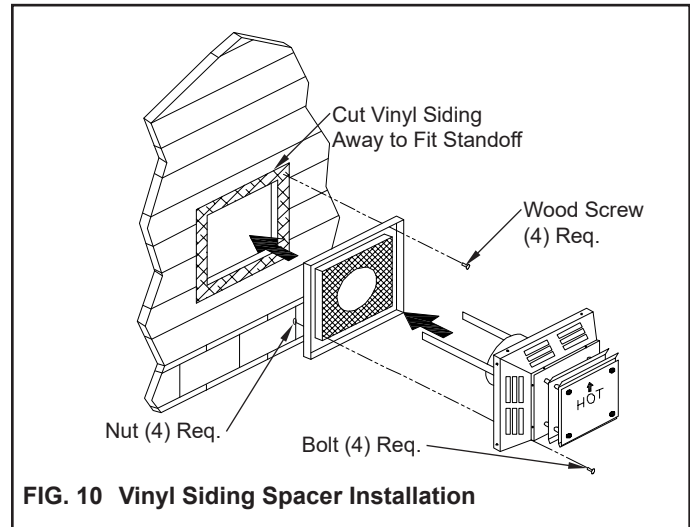

FIG. 10 Vinyl Siding Spacer Installation

CONNECTING THE HORIZONTAL TERMINATION

Prior to connecting the Horizontal Termination to the run of vent pipe, slide the Trim Plate (DCP) onto the vent pipe so that it will provide a finished look to the wall penetration from the interior space.

Next, slide the appliance and vent assembly towards the wall, carefully inserting the vent pipe into the Horizontal Termination. Take care to ensure the vent pipe extends into the Termination collar to result in a minimum of 1-1/4" overlap of vent (See FIG. 11). Secure the connection between the vent pipe and the vent cap by attaching the two sheet metal strips extending from the Termination into the outer wall of the vent pipe.

Use the two (2) sheet metal screws provided to secure the strips to the pipe section. Bend any remaining portion of the sheet metal strip back towards the vent cap, so it will be concealed by the Trim Plate.

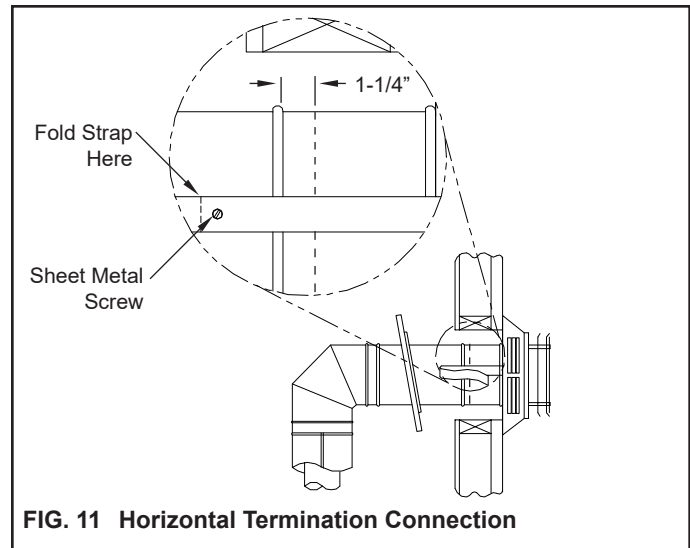

FIG. 11 Horizontal Termination Connection

Slide the Trim Plate flush to wall and secure with sheet metal screws provided. If a Wall Thimble is used, the Trim Plate (which is larger than the Wall Thimble plate) will still be useful to provide a black - decorative style finish to the installation for exposed interior walls.

SNORKEL TERMINATION

For installation requiring a short vertical rise on the exterior wall of the building, Sure-Seal DV provides a Snorkel Termination (DST) as shown in FIG. 12. To install, follow the same instruction procedures as used for the standard Horizontal Termination (DHT).

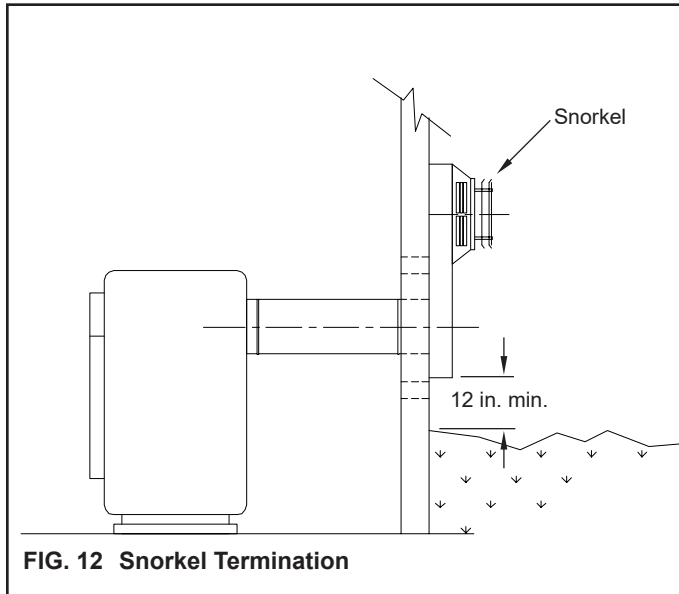

FIG. 12 Snorkel Termination

If the Snorkel termination must be installed below grade (such as for a basement application), proper drainage must be provided to prevent water from entering the Snorkel Termination (See FIG. 13). Do not attempt to enclose the Snorkel Termination within the wall or any other type of enclosure.

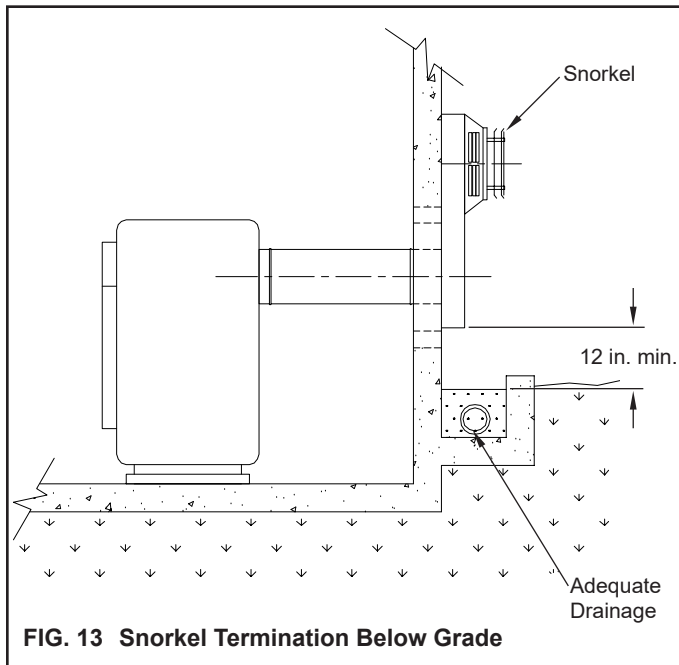

FIG. 13 Snorkel Termination Below Grade

VERTICAL INSTALLATION

For vertical installations (Installations that penetrate through a ceiling and/or roof), proper location of points for penetration must be made. This may be accomplished by first locating where the Direct Vent Appliance will be permanently located. Using a plumb bob, locate the spot on the ceiling directly vertical of the center of the appliance outlet collar. Mark that spot and drill a hole through the ceiling. In a similar manner, the location of the roof penetration can be determined (See FIG. 14).

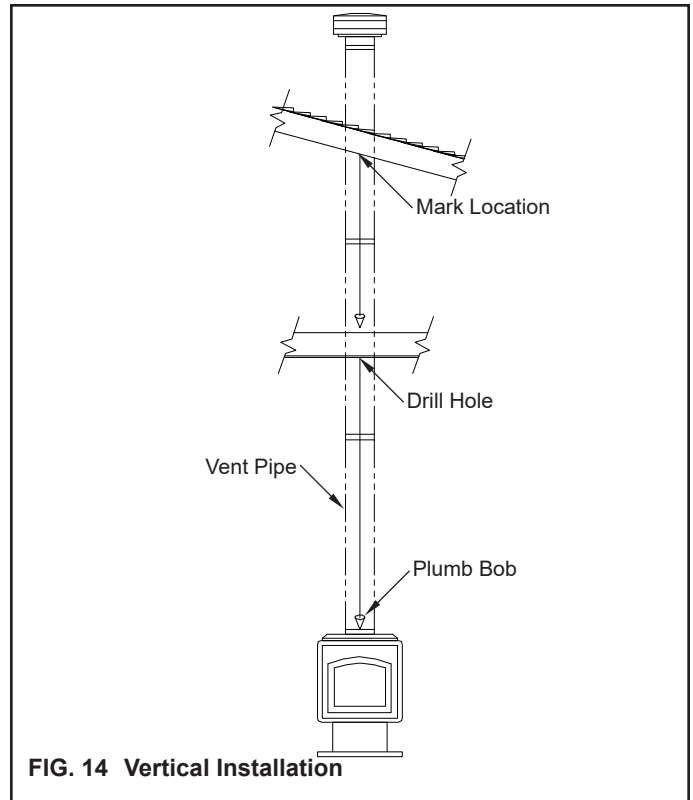

FIG. 14 Vertical Installation

If you encounter interference from ceiling or roof joists, consider repositioning the appliance so that a straight vertical run of vent is all that is needed to finish the installation. Otherwise, elbows to provide offsets will be required to avoid cutting load bearing members and to provide proper clearance to combustible construction.

Be sure to check appliance manufacturer's installation instructions for proper clearance to combustibles when passing through ceiling joists, roofs and enclosures. **Do not pack air spaces with insulation.** Also, check manufacturer's instructions for maximum vertical rise of the venting system and any limitations to maximum offsets.

When penetrating the ceiling, a Firestop must be used. Locate Firestop (DFS) on top of the ceiling joist to prevent entry of insulation. (See FIG. 15). Below the ceiling, a Trim Plate (DCP) is installed to provide a decorative finish to the ceiling penetration. (Refer to FIG. 1 for order of assembly).

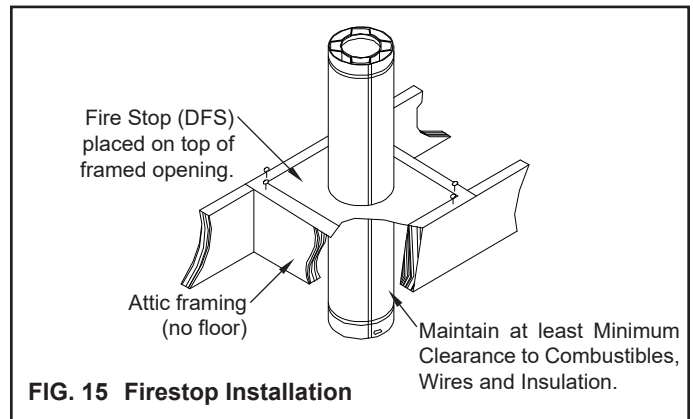

FIG. 15 Firestop Installation

Assemble the appropriate lengths of Sure-Seal DV pipe sections and elbows necessary to reach from the Appliance Outlet up through the Ceiling Support or Firestop. Confirm that each pipe section is fully twist-lock joined as previously detailed in these instructions.

Cut a hole in the roof, centered on the location previously marked. The hole must be large enough to meet minimum clearance to combustibles as specified by the appliance manufacturer. Continue to assemble lengths of pipe and elbows necessary to run up and through the roof line. Galvanized pipe and elbows are recommended for use in the attic and above the roof line. Galvanized steel pipe is especially desirable above the roof line to resist corrosion.

If offsets are necessary to facilitate installation, be certain to support laterally every 4 feet of vent pipe. Also, whenever possible, use 45 degree elbows instead of 90 degree elbows to reduce restriction to airflow of the flue gases and intake air.

Install the Flashing over the pipe and secure to roof using nails or wood screws. Use a non-hardening sealant between the flashing and the roof. Make sure that the roofing material overlaps the top edge of the Flashing Plate. Verify that proper clearances have been maintained at the roofline.

Provide an ample sized bead of approved sealant between the Flashing cone and the vent pipe to seal against rain entry. Take special care to seal tightly around the pipe seam as it passes through the Flashing. Then place a Storm Collar onto the top of the flashing cone and apply a bead of sealant. (NOTE: Metal-Fab MST Tape may also be used to provide seal).

Continue to add pipe sections until the height of the vent meets the minimum building code requirements (See **FIG. 16**). Twist-lock the Vertical Termination onto the last section of vent pipe. It is recommended to further secure the Termination to the pipe section by using two (2) sheet metal screws (#8 x 1/2"). This will help secure the Termination joint as it is exposed to high wind conditions. The screws should be located approximately 3/4" above the bottom edge of the Termination collar. Vent Pipe Sections in excess of 4 ft. above the roof should be securely guyed to prevent unnecessary movement. Attach guying to vent. Never attach guying to the cap.

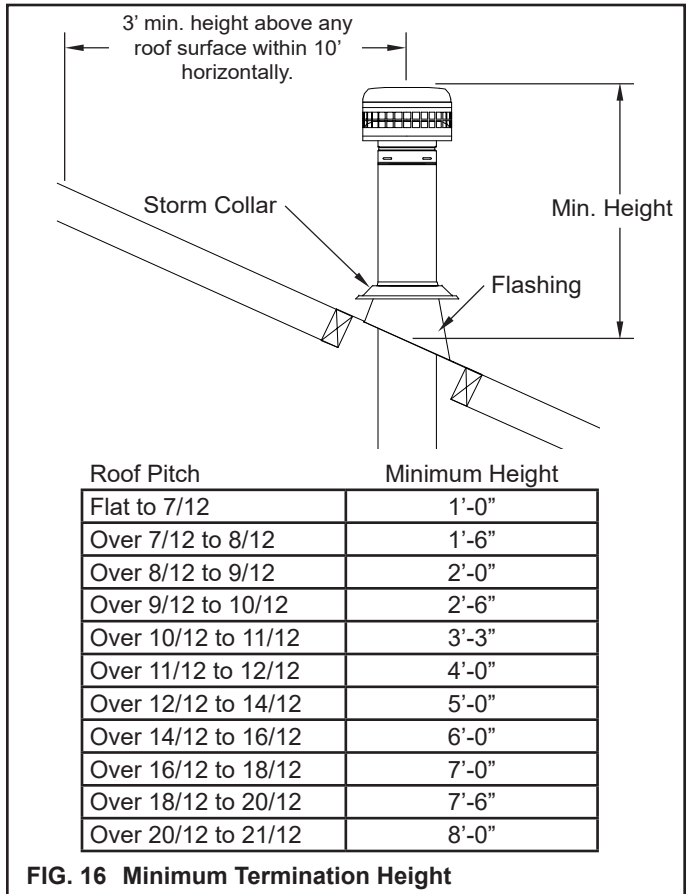

FIG. 16 Minimum Termination Height

PRODUCT LABELS

All components are labeled with the appropriate identification information and OMNI/Warnock/UL Hersey listing data where applicable. Pipe and fittings which are painted black have the label placed on the inside of the outer sleeve near the male end.

GENERAL MAINTENANCE

Following these instructions and maintenance recommendations will provide years of service for this venting system. Conduct an inspection of the venting system on a semi-annual basis. Recommended areas to inspect include:

- Check areas of the venting system which are exposed to the elements for corrosion. These will appear as rust spots or streaks, and in extreme cases, holes. If such components are found, they should be replaced immediately.
- Remove the Vertical Termination and shine a light down the vent to inspect for any obstructions to the vent and intake air path. Remove any foreign material that may have accumulated.
- Check for excessive condensation, such as water droplets forming in the inner liner and subsequently dripping out at the joints. Continuous condensate can cause corrosion of vent components. It may be caused by excessive lateral runs, too many elbows, and exterior venting exposed to cold weather. It is recommended that venting systems be enclosed below the roof line to limit condensation and protect against damage.
- Inspect joints to verify that no pipe section or fitting has been disturbed and consequently loosened. Also, check mechanical supports such as wall straps and clamps for rigidity.

IMPORTANT: THE LISTING FOR THIS PRODUCT IS VOID IF COMPONENTS OTHER THAN THOSE SUPPLIED AS LISTED COMPONENTS BY METAL-FAB, INC. IS USED. ALL WARRANTIES, STATED OR IMPLIED, ARE VOID IF THIS PRODUCT AND THE APPLIANCES TO WHICH IT IS CONNECTED ARE NOT INSTALLED IN ACCORDANCE WITH THEIR RESPECTIVE INSTRUCTIONS AND LOCAL CODE REQUIREMENTS.



Intertek

CERTIFIED TO:
ANSI Z21.88 & UL2112





An OLYMPIC**STEEL** Company

P.O. Box 1138 • WICHITA, KANSAS 67201
PHONE: 316-943-2351 • 800-835-2830
FAX (316) 943-2717
info@metal-fabinc.com
www.metal-fabinc.com